



## **The Benchmark Collection**

**Experience  
The Ultimate  
in Vinyl  
Component  
Parts**



# Profiles, Colors and Accessories

## STANDARD PROFILES

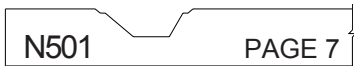
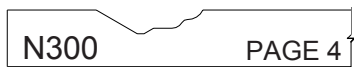
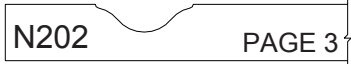
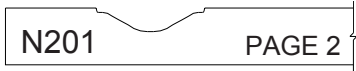
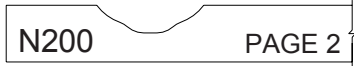

## CONTEMPORARY PROFILES

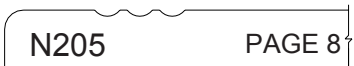

## SHAKER PROFILES

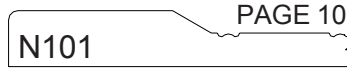

## OUTSIDE PROFILES



\*SEE SPECIFIED INSIDE PROFILE PAGE TO DETERMINE WHICH INSIDE AND OUTSIDE PROFILES ARE COMPATIBLE

## MULLIONS

PAGE 12

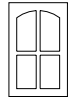

## LAZY SUSANS END PANELS

PAGE 13



## MULTIPLE PANELS

PAGE 14



## MOLDINGS VALANCES FLUTES

PAGE 13



## COLORS AVAILABLE

PAGE 15



## N200



The code for this door would be:  
**B200/N200/S01**  
**HARDROCK MAPLE**

### STYLES AVAILABLE

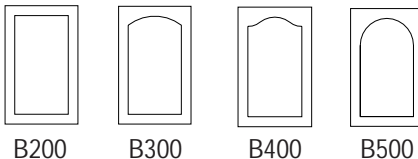

Note: this profile features round corners

### MINIMUM DOOR SIZES

B200	8 1/16	x	8 1/16
B300	8 13/16	x	8 1/16
B400	9 13/16	x	8 1/16
B500	8 13/16	x	8 1/16

\*Above minimum leaves a 3/4" center rail & 2.4" equal margins

### OUTSIDE PROFILES AVAILABLE

S01, S02, S03, S04, S05, S06, S07, S08

\*See page 1 for detailed drawings

### MINIMUM ROUTERED DRAWER SIZE

8 1/6 X 5 1/2

\*Above minimum leaves a 1/2" center rail

\*\* Drawers feature reduced horizontal rails

\*\*\*Grain is horizontal - unless specified

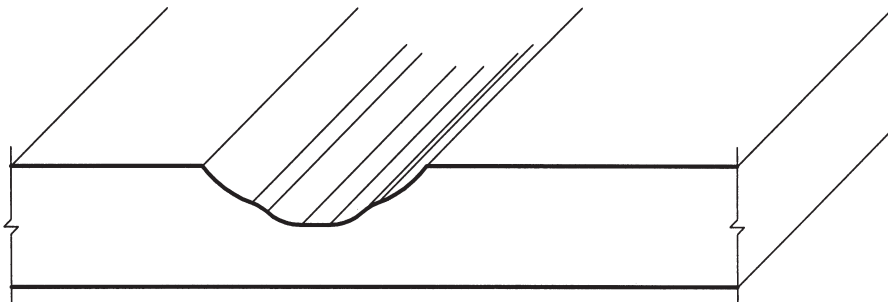

## N201



The code for this door would be:  
**B200/N201/S01**  
**WHITE MATTE**

### STYLES AVAILABLE

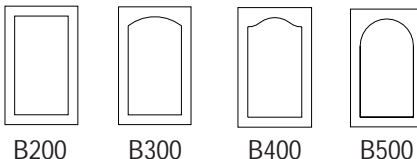

Note: this profile features round corners

### MINIMUM DOOR SIZES

B200	8 1/8	x	8 1/8
B300	8 7/8	x	8 1/8
B400	9 7/8	x	8 1/8
B500	8 7/8	x	8 1/8

\*Above minimum leaves a 3/4" center rail & 2.25" equal margins

### OUTSIDE PROFILES AVAILABLE

S01, S02, S03, S04, S05, S06, S07, S08

\*See page 1 for detailed drawings

### MINIMUM ROUTERED DRAWER SIZE

8 1/8 X 5 7/8

\*Above minimum leaves a 1/2" center rail

\*\* Drawers feature reduced horizontal rails

\*\*\*Grain is horizontal - unless specified

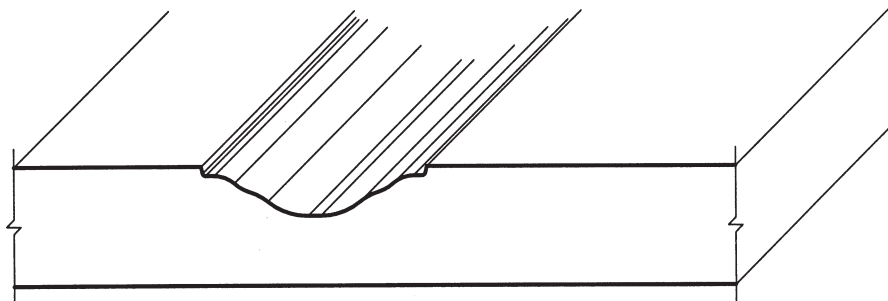



# Standard Profiles Cont.

## N202



The code for this door would be:  
**B200/N202/S01**  
**AMBERWOOD**

### STYLES AVAILABLE

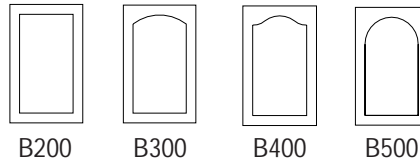

Note: this profile features round corners

### OUTSIDE PROFILES AVAILABLE

S01, S02, S03, S04, S05, S06, S07, S08

\*See page 1 for detailed drawings

### MINIMUM DOOR SIZES

B200	7 7/8	x	7 7/8
B300	8 5/8	x	7 7/8
B400	9 5/8	x	7 7/8
B500	8 5/8	x	7 7/8

\*Above minimum leaves a 3/4" center rail & 2.25" equal margins

### MINIMUM ROUTERED DRAWER SIZE

7 7/8 X 5 5/8

\*Above minimum leaves a 1/2" center rail  
\*\* Drawers feature horizontal reduced rails  
\*\*\* Grain is horizontal - unless specified

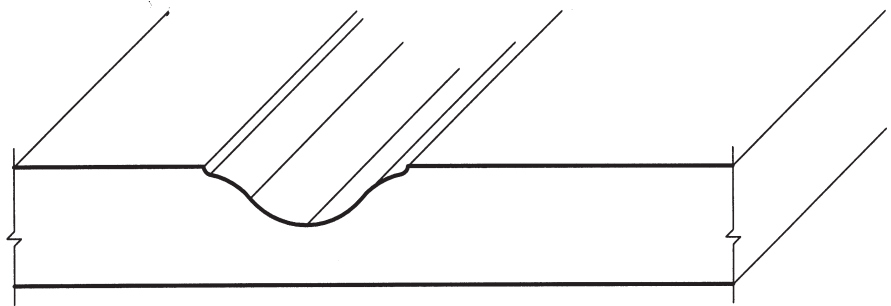

## N203



The code for this door would be:  
**B200/N203/S01**  
**SNOW**

### STYLES AVAILABLE

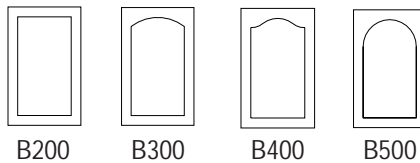

Note: this profile features round corners

### OUTSIDE PROFILES AVAILABLE

S01, S02, S03, S04, S05, S06, S07, S08

\*See page 1 for detailed drawings

### MINIMUM DOOR SIZES

B200	7 5/8	x	7 5/8
B300	8 3/8	x	7 5/8
B400	9 3/8	x	7 5/8
B500	8 3/8	x	7 5/8

\*Above minimum leaves a 3/4" center rail & 2.25" equal margins

### MINIMUM ROUTERED DRAWER SIZE

7 5/8 X 5 3/8

\*Above minimum leaves a 1/2" center rail  
\*\* Drawers feature horizontal reduced rails  
\*\*\* Grain is horizontal - unless specified

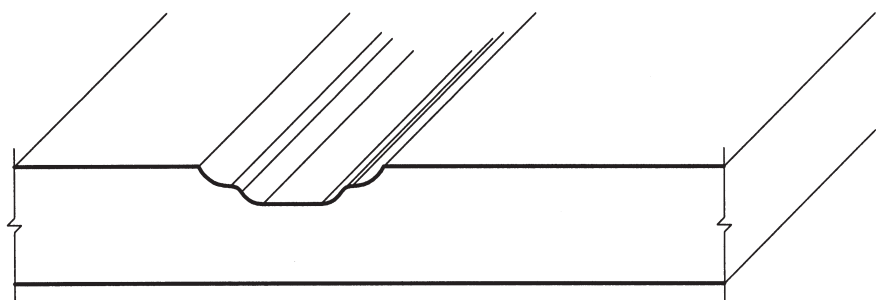



## N204

### MINIMUM DOOR SIZES

B200	6 1/2	x	6 1/2
B300	7 1/4	x	6 1/2
B400	8 1/4	x	6 1/2
B500	7 1/4	x	6 1/2

\*Above minimum leaves a 3/4" center rail & 2" equal margins

### MINIMUM ROUTERED DRAWER SIZE

6 1/2 X 4 5/8

\*Above minimum leaves a 1/2" center rail  
 \*\* Drawers feature reduced horizontal rails  
 \*\*\*Grain is horizontal - unless specified

### STYLES AVAILABLE

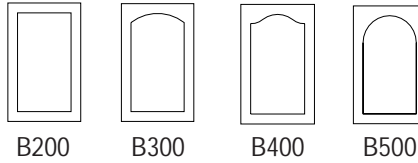

Note: this profile features round corners

### OUTSIDE PROFILES AVAILABLE

S01, S02, S03, S04, S05, S06, S07, S08

\*See page 1 for detailed drawings



The code for this door would be:  
**B200/N204/S01**  
**TIDEWOOD**

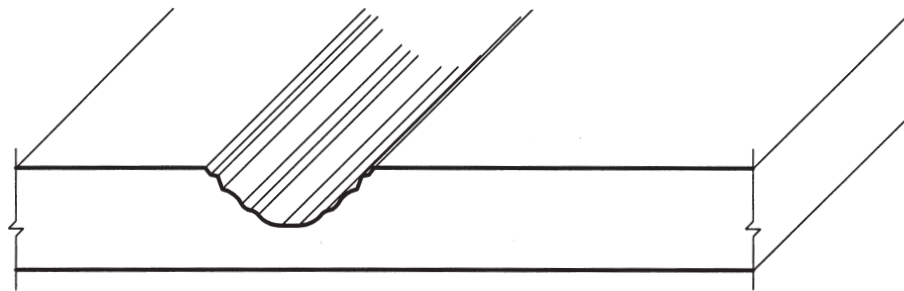

### MINIMUM DOOR SIZES

B200	8 1/8	x	8 1/8
B300	8 7/8	x	8 1/8
B400	9 7/8	x	8 1/8
B500	8 7/8	x	8 1/8

\*Above minimum leaves a 3/4" center rail & 2.25" equal margins

### MINIMUM ROUTERED DRAWER SIZE

8 1/8 X 5 7/8

\*Above minimum leaves a 1/2" center rail  
 \*\* Drawers feature reduced horizontal rails  
 \*\*\*Grain is horizontal - unless specified

### STYLES AVAILABLE

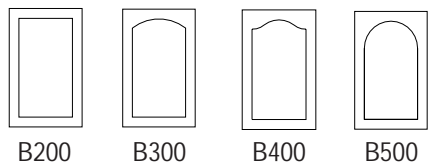

Note: this profile features square corners

### OUTSIDE PROFILES AVAILABLE

S01, S02, S03, S04, S05, S06, S07, S08

\*See page 1 for detailed drawings

## N300



The code for this door would be:  
**B200/N300/S01**  
**HAYWARD CHERRY**

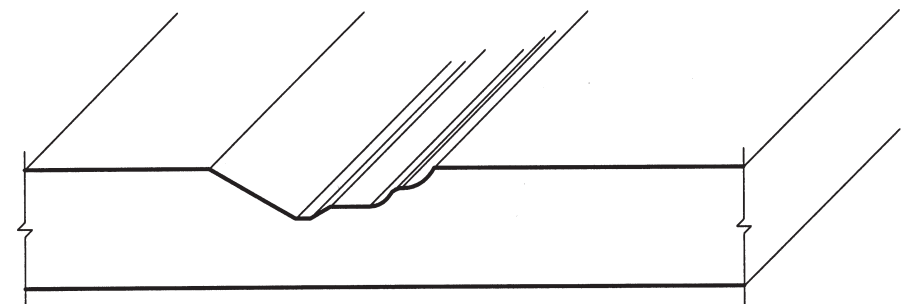



# Standard Profiles Cont.

## N301



The code for this door would be:  
**B200/N301/S01**  
**AMERICAN NATURAL**

### STYLES AVAILABLE

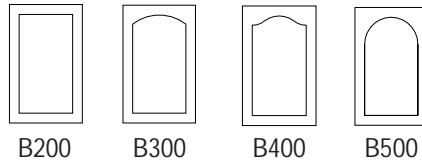

Note: this profile features square corners

### MINIMUM DOOR SIZES

B200	8 1/8	x	8 1/8
B300	8 7/8	x	8 1/8
B400	9 7/8	x	8 1/8
B500	8 7/8	x	8 1/8

\*Above minimum leaves a 3/4" center rail & 2.25" equal margins

### OUTSIDE PROFILES AVAILABLE

S01, S02, S03, S04, S05, S06, S07, S08

\*See page 1 for detailed drawings

### MINIMUM ROUTERED DRAWER SIZE

8 1/8 X 5 7/8

\*Above minimum leaves a 1/2" center rail  
\*\* Drawers feature reduced horizontal rails  
\*\*\* Grain is horizontal - unless specified

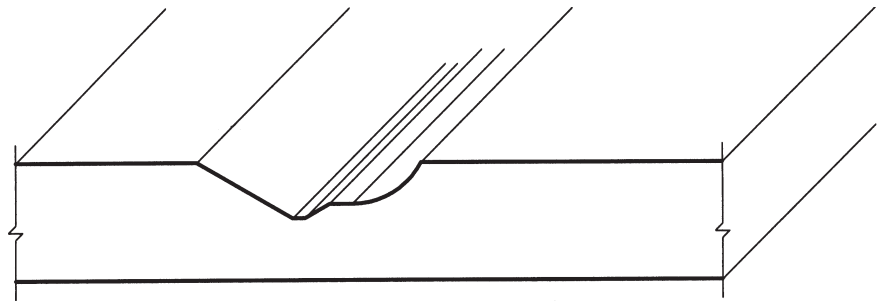

## N400



The code for this door would be:  
**B200/N400/S01**  
**COGNAC**

### STYLES AVAILABLE

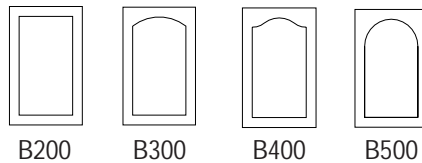

Note: this profile features square corners

### MINIMUM DOOR SIZES

B200	7	x	7
B300	7 3/4	x	7
B400	8 3/4	x	7
B500	7 3/4	x	7

\*Above minimum leaves a 3/4" center rail & 2" equal margins

### OUTSIDE PROFILES AVAILABLE

S01, S02, S03, S04, S05, S06, S07, S08

\*See page 1 for detailed drawings

### MINIMUM ROUTERED DRAWER SIZE

7 X 4 3/4

\*Above minimum leaves a 1/2" center rail  
\*\* Drawers feature reduced horizontal rails  
\*\*\* Grain is horizontal - unless specified

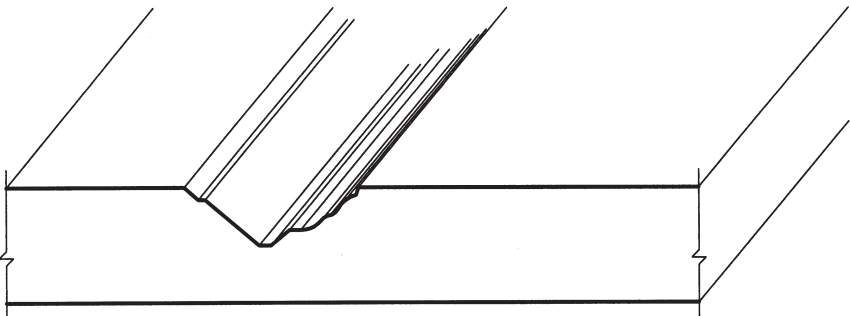



## N401

### MINIMUM DOOR SIZES

B200	7 1/2	x	7 1/2
B300	8 1/4	x	7 1/2
B400	9 1/4	x	7 1/2
B500	8 1/4	x	7 1/2

\*Above minimum leaves a 3/4" center rail & 2.25" equal margins

### STYLES AVAILABLE

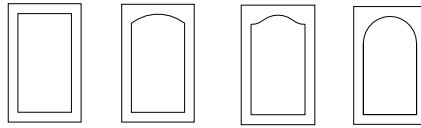

B200 B300 B400 B500

Note: this profile features square corners



The code for this door would be:  
**B200/N401/S01**  
**PORT MAPLE**

### MINIMUM ROUTERED DRAWER SIZE

7 1/2 X 4 3/4

\*Above minimum leaves a 1/2" center rail  
 \*\* Drawers feature reduced horizontal rails  
 \*\*\* Grain is horizontal - unless specified

### OUTSIDE PROFILES AVAILABLE

S01, S02, S03, S04, S05, S06, S07, S08

\*See page 1 for detailed drawings

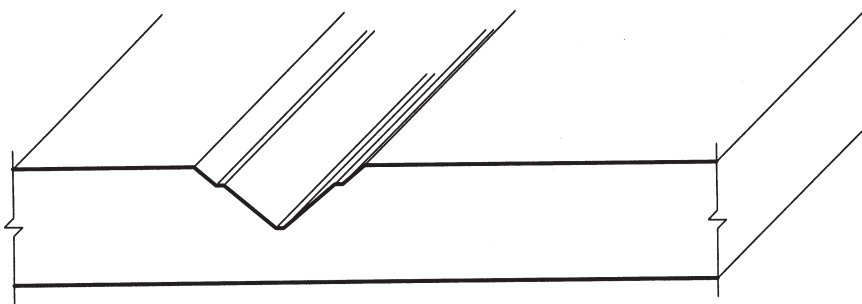

### MINIMUM DOOR SIZES

B200	8 1/4	x	8 1/4
B300	9	x	8 1/4
B400	10	x	8 1/4
B500	9	x	8 1/4

\*Above minimum leaves a 3/4" center rail & 2.25" equal margins

### STYLES AVAILABLE

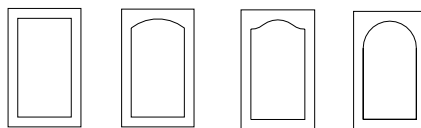

B200 B300 B400 B500

Note: this profile features square corners



The code for this door would be:  
**B200/N500/S01**  
**HAYWARD CHERRY**

### MINIMUM ROUTERED DRAWER SIZE

8 1/4 X 6

\*Above minimum leaves a 1/2" center rail  
 \*\* Drawers feature reduced horizontal rails  
 \*\*\* Grain is horizontal - unless specified

### OUTSIDE PROFILES AVAILABLE

S01, S02, S03, S04, S05, S06, S07, S08

\*See page 1 for detailed drawings

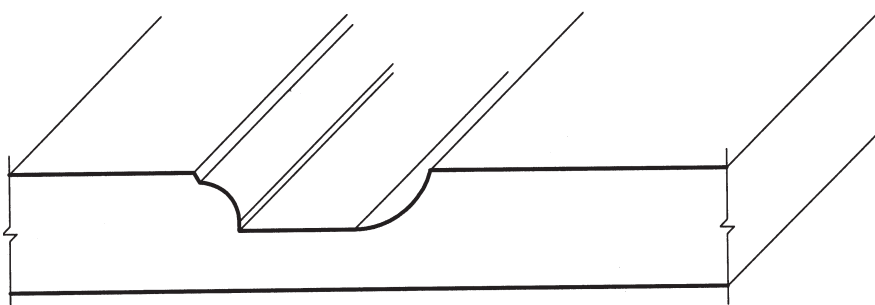



# Standard Profiles Cont.

## N501



The code for this door would be:  
**B200/N501/S01**  
**HARDROCK MAPLE**

### STYLES AVAILABLE

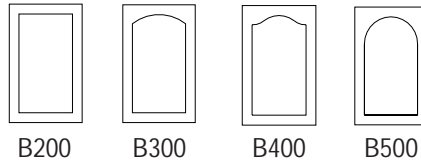

Note: this profile features square corners

### MINIMUM DOOR SIZES

B200	8 1/2	x	8 1/2
B300	9 1/4	x	8 1/2
B400	10 1/4	x	8 1/2
B500	9 1/4	x	8 1/2

\*Above minimum leaves a 3/4" center rail & 2.25" equal margins

### OUTSIDE PROFILES AVAILABLE

S01, S02, S03, S04, S05, S06, S07, S08

\*See page 1 for detailed drawings

### MINIMUM ROUTERED DRAWER SIZE

8 1/2 X 6 1/4

\*Above minimum leaves a 1/2" center rail  
\*\* Drawers feature reduced horizontal rails  
\*\*\* Grain is horizontal - unless specified

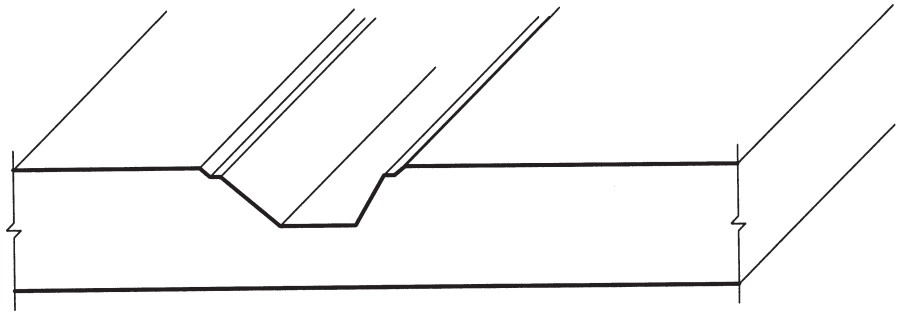

Kitchen features shaker style door and drawer fronts in white matte  
B602/N101/S01



Bathroom features slab style door and drawer fronts in antique white  
B100/N000/S02





## MINIMUM SIZE

B100	1	x	1
B130	1	x	1
B131	1	x	1

## STYLES AVAILABLE



B100 Profile  
All 4 Sides



B130 Profile  
Top/Bottom



B131 Profile  
Left/Right

Note: No inside profile

## OUTSIDE PROFILES AVAILABLE

S01, S02, S03, S04, S05, S06, S07, S08

\*See page 1 for detailed drawings

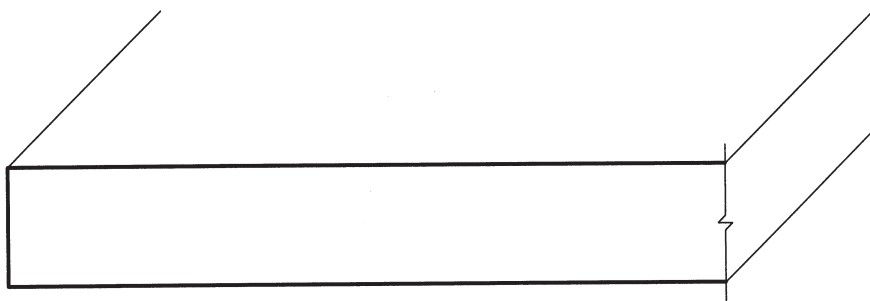

## N000



The code for this door would be:  
**B100/N000/S02**  
**WHITE MATTE**

## MINIMUM SIZE

B110	5	x	3
------	---	---	---

\*1 7/8 edge margin  
\*\*Drawer grain is horizontal - unless specified

## STYLES AVAILABLE

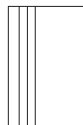

B110

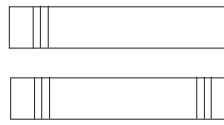

Specify single or double  
on drawer fronts

## OUTSIDE PROFILES AVAILABLE

S01, S02, S03, S04, S05, S06, S07, S08

\*See page 1 for detailed drawings

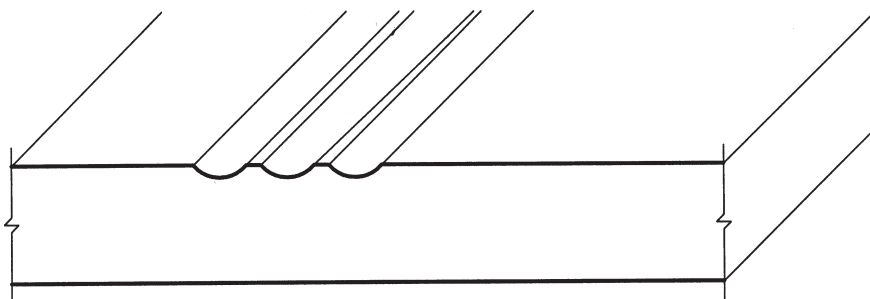

## N205



The code for this door would be:  
**B110/N205/S06**  
**ALMOND MATTE**



# Contemporary Profiles Cont.

## N206



The code for this door would be:  
**B120/N206/S05**  
**WHITE WOODGRAIN**

### STYLES AVAILABLE



B120

### MINIMUM SIZE

B120      4      x      8

\*Drawer grain is horizontal unless specified

\*\*Drawers feature outside profile only

### OUTSIDE PROFILES AVAILABLE

S01, S02, S03, S04, S05, S06, S07, S08

\*See page 1 for detailed drawings

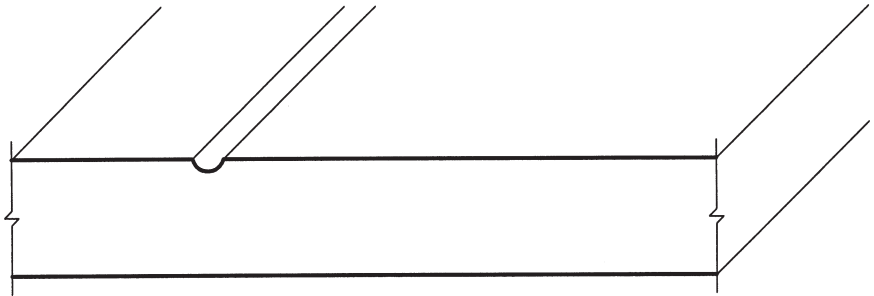

Office features slab style door and  
drawer fronts in hardrock maple  
B100/N00/S02



Kitchen features doors and drawer  
fronts in antique white  
B200/N400/S01



## MINIMUM DOOR SIZES

B600/B602      7 1/2   x   7 1/2

\*Above minimum leaves a 3" center and 2.25" equal margins

## MINIMUM DRAWER SIZE

7 1/2 X 5 1/2

\*Drawers feature reduced horizontal rails  
\*\*Grain is horizontal - unless specified

## STYLES AVAILABLE

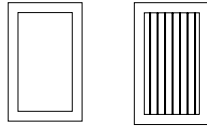

B600      B602  
Flat panel      Beaded panel

Note: this profile features slightly rounded corners

## OUTSIDE PROFILES AVAILABLE

S01, S02, S03, S04, S05, S06, S07, S08

\*See page 1 for detailed drawings

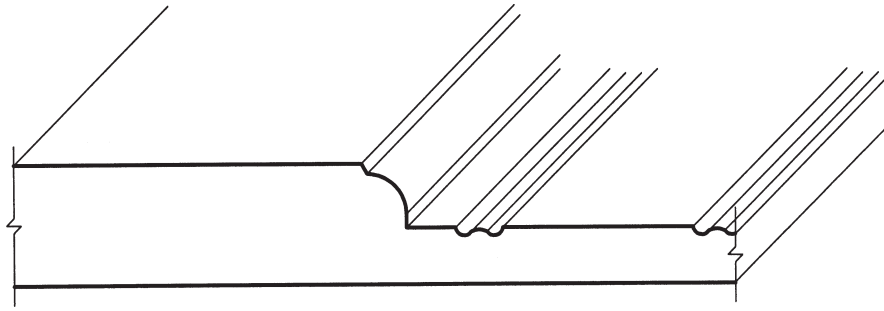

# N100



The code for this door would be:  
**B602/N100/S04**  
**SNOW**

## MINIMUM DOOR SIZES

B600/B602      7 1/2   x   7 1/2

\*Above minimum leaves a 3" center rail and 2.25" equal margins

## MINIMUM DRAWER SIZE

7 1/2 X 5 1/2

\*Drawers feature reduced horizontal rails  
\*\*Grain is horizontal - unless specified

## STYLES AVAILABLE

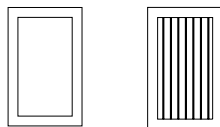

B600      B602  
Flat panel      Beaded panel

Note: this profile features square corner look

## OUTSIDE PROFILES AVAILABLE

S01, S02, S03, S04, S05, S06, S07, S08

\*See page 1 for detailed drawings

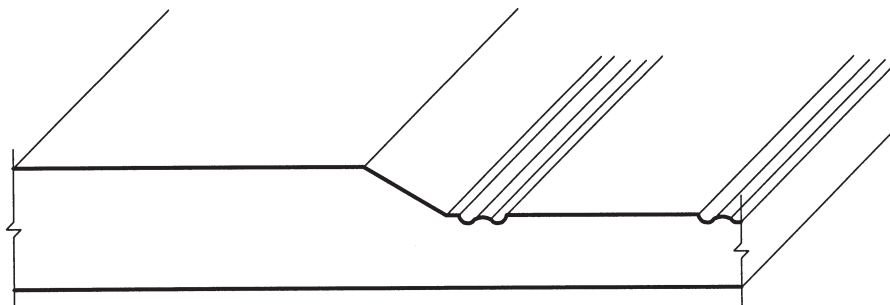

# N101



The code for this door would be:  
**B602/N101/S01**  
**SANIBEL MAPLE**



# Shaker Profiles Cont.

## N102



The code for this door would be:  
**B602/N102/S04**  
**WHITE MATTE**

### STYLES AVAILABLE

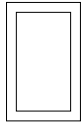

B600  
Flat panel

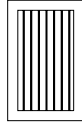

B602  
Beaded panel

Note: this profile features tight inside corners

### OUTSIDE PROFILES AVAILABLE

S01, S02, S03, S04, S05, S06, S07, S08

\*See page 1 for detailed drawings

### MINIMUM DOOR SIZES

B600/B602      7 1/2 x 7 1/2

\*Above minimum leaves a 3" center and 2.25" equal margins

### MINIMUM DRAWER SIZE

7 1/2 X 5 1/2

\*Drawers feature reduced horizontal rails

\*\*Grain is horizontal - unless specified

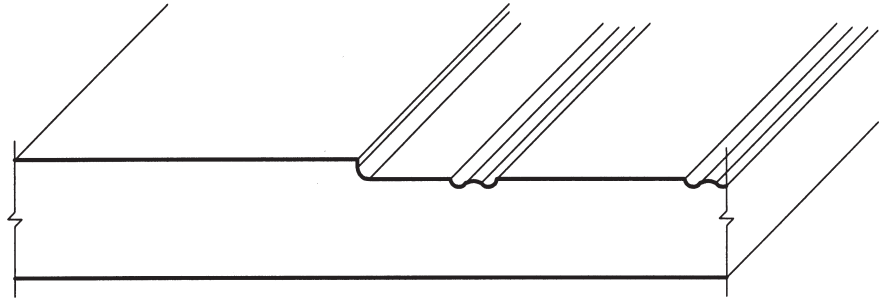

## N103



The code for this door would be:  
**B642/N103/S04**  
**SUGAR MAPLE**

### STYLES AVAILABLE

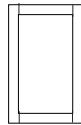

B640  
Flat panel

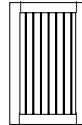

B642  
Beaded panel

Note: this profile features tight inside corners

### OUTSIDE PROFILES AVAILABLE

S01, S02, S03, S04, S05, S06, S07, S08

\*See page 1 for detailed drawings

### MINIMUM DOOR SIZES

B640/B642      7 1/2 x 7 1/2

\*Above minimum leaves a 3" center and 2.25" equal margins

### MINIMUM DRAWER SIZE

7 1/2 X 5 1/2

\*Drawers feature reduced horizontal rails

\*\*Grain is horizontal - unless specified

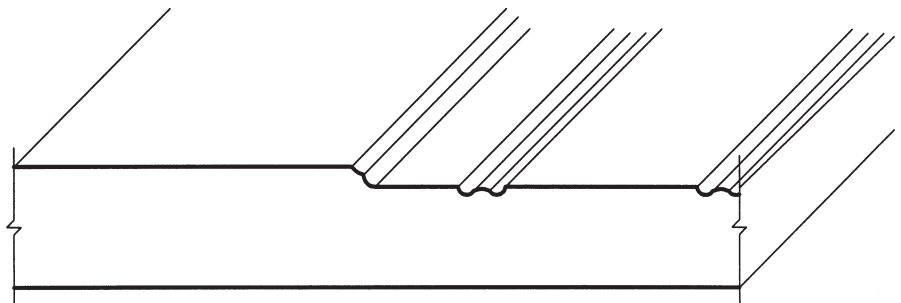



## GIVE YOUR CABINETS A UNIQUE TOUCH

Glazing is a hand-applied finish used to add depth, enhance woodgrain, highlight molding or create a “rustic” appearance. JB Cutting offers two glazed looks, detail and rustic. Because our process is not automated, each piece reflects a distinct style, conveying an overall hand-crafted look. Glazing is a style and price increase. The end result is worth the added expense!

Specialty Glazes and color combinations available upon request  
 For example: butterscotch and chocolate on antique white

Any part can be glazed  
 For example: crown moldings, flutes, valances, end panels, etc.

## DETAIL GLAZED LOOK

To achieve the “detail” look, almost all of the glaze is removed during the glazing process. Most of the glaze remains in the recessed areas of the door. Actual product may vary from photo.



GLAZES/COLORS	
Chocolate Brown on Antique White	
Auburn Red on Light Pear	
Chocolate Brown on Light Pear	
Onyx on Medium Cherry	

The code for this door would be:

**B200/N501/S01**

**CHOCOLATE BROWN ON ANTIQUE WHITE/DETAIL**

### INSIDE PROFILES AVAILABLE

N201, N202, N400, N501

### OUTSIDE PROFILES AVAILABLE

S01, S02, S03, S04, S05, S06, S07, S08,

### STYLES AVAILABLE

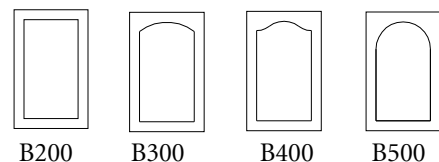

B200

B300

B400

B500



# Glazed Thermofoil Doors

## RUSTIC GLAZED LOOK

To achieve the “rustic” look, hardly any glaze is removed during the glazing process. This creates a more antiqued appearance adding vibrance and depth. Actual product may vary from photo.



### GLAZES/COLORS

Chocolate Brown on  
Antique White



Auburn Red on  
Light Pear



Chocolate Brown on  
Light Pear



Onyx on  
Medium Cherry



The code for this door would be:

**B200/N202/S01**

**CHOCOLATE BROWN ON LIGHT PEAR/RUSTIC**

#### INSIDE PROFILES AVAILABLE

N201, N202, N400, N501

#### OUTSIDE PROFILES AVAILABLE

S01, S02, S03, S04, S05, S06, S07, S08,

#### STYLES AVAILABLE

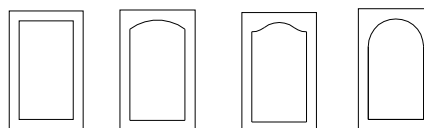

B200

B300

B400

B500



Bathroom features auburn red on light pear thermofoil in the rustic glazed look B200/N501/S01



## SQUARE

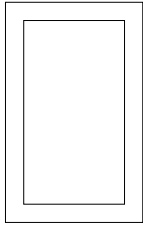

B201  
MINIMUM  
8.81 X 8.81

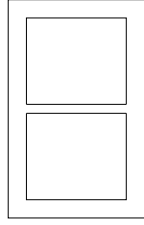

B202  
MINIMUM  
8.81 X 13.81

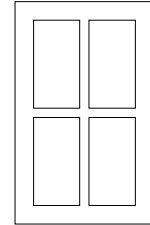

B204  
MINIMUM  
13.81 X 13.81

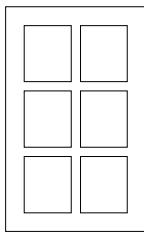

B206  
MINIMUM  
13.81 X 18.81

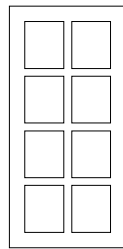

B208  
MINIMUM  
13.81 X 23.81

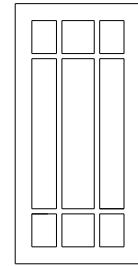

B209  
MINIMUM  
22.81 X 22.81

## ARCH

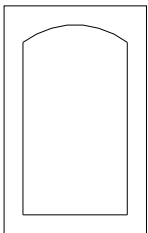

B301  
MINIMUM  
8.81 X 8.81

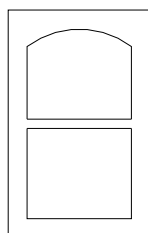

B302  
MINIMUM  
8.81 X 8.81

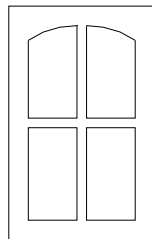

B304  
MINIMUM  
12 X 14.81

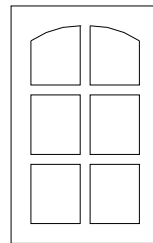

B306  
MINIMUM  
12 X 18.81

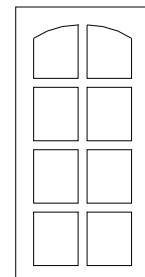

B308  
MINIMUM  
13.81 X 22.81

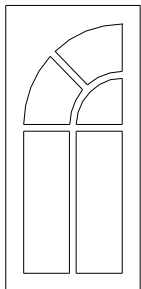

B351  
MIN: 13.81 X 18.81

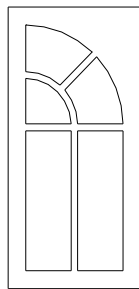

B352

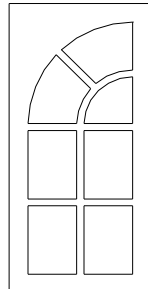

B371

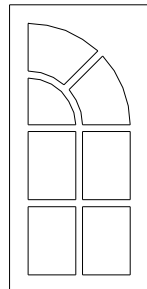

B372

MIN: 13.81 X 18.81

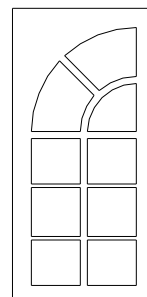

B391

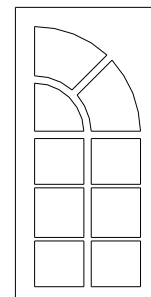

B392

MIN: 13.81 X 18.81



# Mullions Cont.

## CATHEDRAL

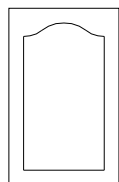

B401  
MINIMUM  
8.81 X 8.81

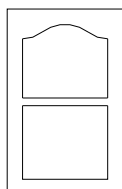

B402  
MINIMUM  
8.81 X 8.81

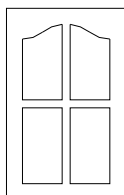

B404  
MINIMUM  
13 X 14.81

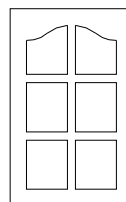

B406  
MINIMUM  
13 X 18.81

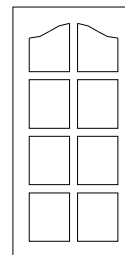

B408  
MINIMUM  
13 X 22.81

## MOON

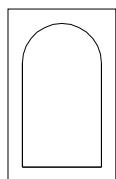

B501  
MINIMUM  
8.81 X 8.81

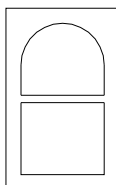

B502  
MINIMUM  
8.81 X 8.81

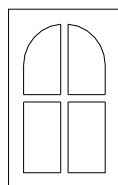

B504  
MINIMUM  
14 X 14.81

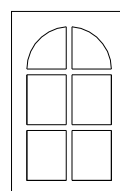

B506  
MINIMUM  
14 X 18.81

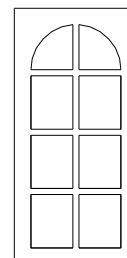

B508  
MINIMUM  
14 X 22.81

## SHAKER

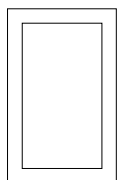

B601  
MINIMUM  
7.5 X 7.5

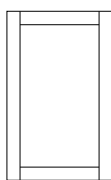

B641  
MINIMUM  
7.5 X 7.5

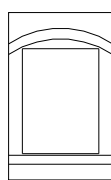

B125  
MINIMUM  
7.5 X 7.5

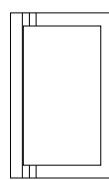

B115  
MINIMUM  
7.5 X 7.5

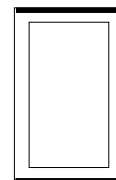

B141  
RADIUS  
TOP/BOTTOM  
MINIMUM  
7.5 X 7.5

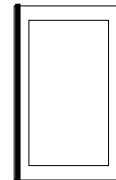

B151  
RADIUS  
LEFT/RIGHT  
MINIMUM  
7.5 X 7.5

## CONTEMPORARY



# Multiple Panels



## SQUARE

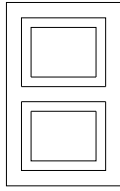

B220

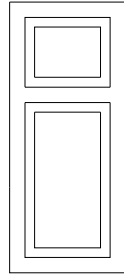

\*\* B221

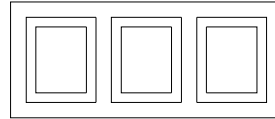

B222

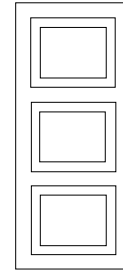

\*\* B225

## ARCH

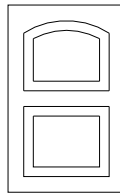

B320

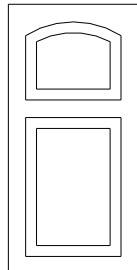

\*\* B321

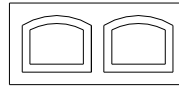

B322

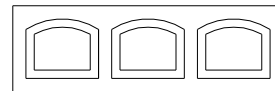

B323

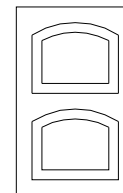

B324

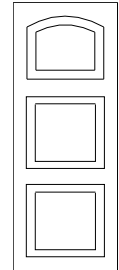

\*\* B325

## CATHEDRAL

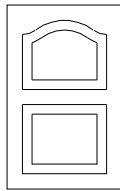

B420

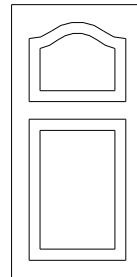

\*\* B421

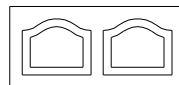

B422

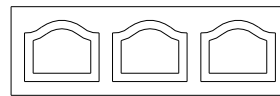

B423

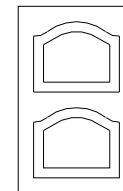

B424

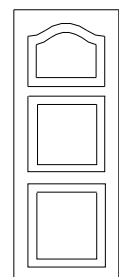

\*\* B425

## MOON

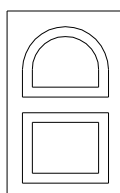

B520

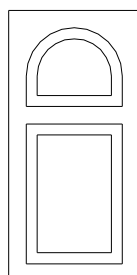

\*\* B521

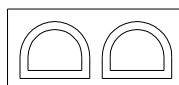

B522

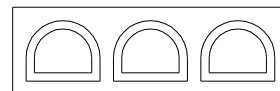

B523

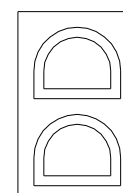

B524

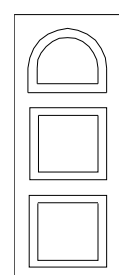

\*\* B525

## SHAKER

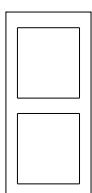

B620

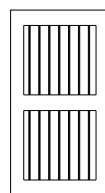

B621

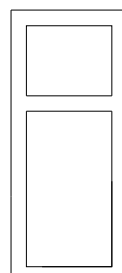

\*\*B622

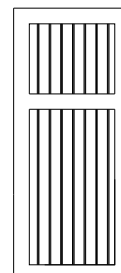

\*\*B623

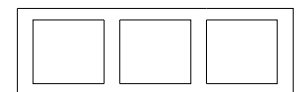

B624

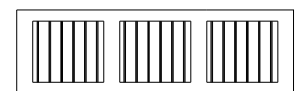

B625

\*\*VARIABLE, PLEASE SPECIFY MEASUREMENTS WHEN ORDERING



# Lazy Susans and Crown Moldings

## SLAB



B105

## SQUARE

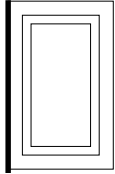

B230

## ARCH

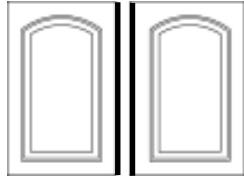

B330

B331

## CATHEDRAL

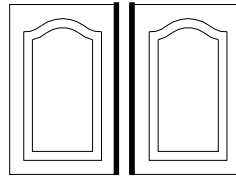

B430

B431

## MOON

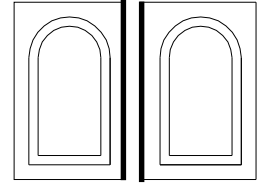

B530

B531

## SHAKER

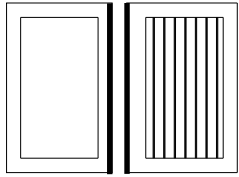

B630

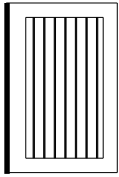

B631

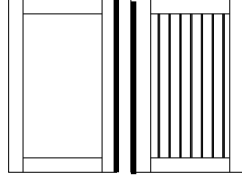

B632

B633

\*STRAIGHT EDGE AS SPECIFIED UNLESS OTHERWISE NOTED

\*\*EQUAL MARGINS UNLESS OTHERWISE NOTED

## CROWN MOLDINGS (ALL MEASUREMENTS IN INCHES)

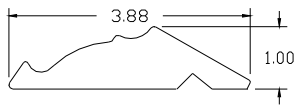

A100

TOPMOUNT

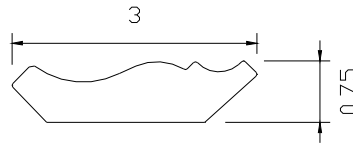

A101

LARGE FACE MOUNT

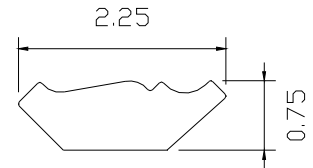

A102

SMALL FACE MOUNT

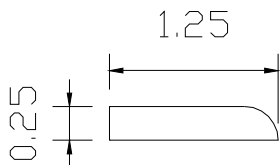

A103

SCRIBE MOLDING

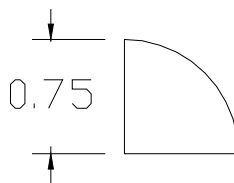

A104

SHOE MOLDING

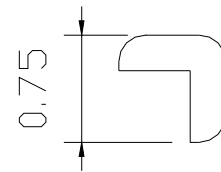

A105

OUTSIDE CORNER MOLDING

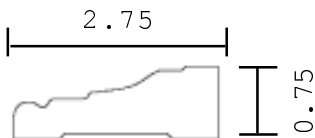

A106

BASE MOLDING

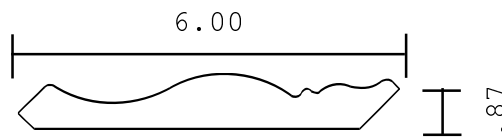

A107

EXTRA LARGE FACE MOUNT

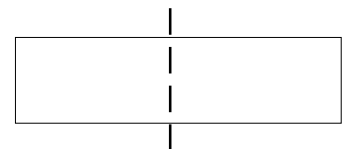

B100

\*SLAB MOLDING

ORDERED AS A SLAB DWR FRONT 94 X ?  
CUT IN HALF PER CUSTOMER SPECS  
ANY EDGE DETAIL IS AVAILABLE.

# Valances, Flutes, and Wineracks



## VALANCES

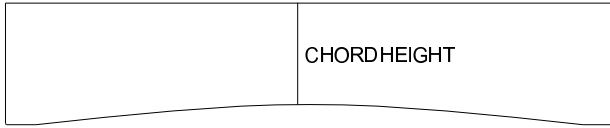

B028  
SINGLE ARCH VALANCE

WHEN ORDERING SPECIFY  
OUTSIDE EDGE DETAIL  
AND CHORD HEIGHT



B029  
DOUBLE ARCH VALANCE

WHEN ORDERING SPECIFY  
OUTSIDE EDGE DETAIL  
AND CHORD HEIGHT

## FLUTES (ALL FLUTES ARE 2" FROM EACH END AND 3/4" ON CENTER)

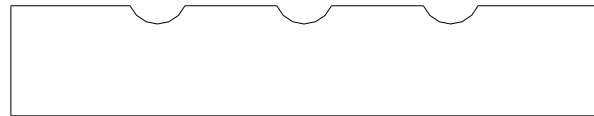
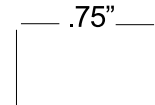
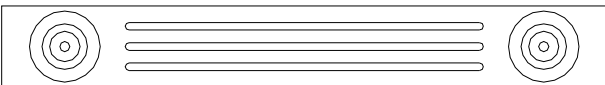
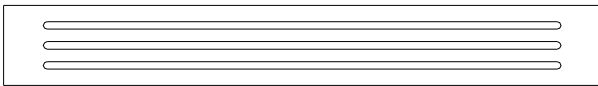

B160  
3" WIDE TO 94" IN LENGTH  
4" WIDE TO 94" IN LENGTH  
ALSO AVAILABLE IN CUSTOM SIZES  
NOTE: ROSETTES CAN BE ORDERED INDIVIDUALLY - 3" X 3"

## WINERACKS

18" LONG - SPACE FOR 4 BOTTLES  
24" LONG - SPACE FOR 6 BOTTLES  
30" LONG - SPACE FOR 7 BOTTLES  
PLEASE SPECIFY LENGTH WHEN ORDERING  
(CUSTOM SIZES AVAILABLE)



## COLORS AVAILABLE

### CATEGORY 1

VINYL	LAMINATE	MELAMINE
White Matte	Pionite SW 836 Winter White	Flakeboard W100

### CATEGORY 2

VINYL	LAMINATE	MELAMINE
Snow	Formica 949-58 White	Flakeboard W500
White Woodgrain	Pionite SW 811 White	Flakeboard W400 w/Cathedral Grain Texture
Antique White	Wilsonart 1572-60 Antique White	Panolam S463 Antique White
Almond Matte	Wilsonart D30-60 Natural Almond	Panolam S445 Almond
Northern Gray	Pionite SG241, Formica 927-58	Panolam S548 Custom Grey, Tafisa L202
Black Matte	Formica 909-42 Black Sparkle	Panolam S405 Black

### CATEGORY 3

VINYL	LAMINATE	MELAMINE
Ivory	Formica 463-58 Sail White	Panolam S463
Tidewood	Formica 7182-58 Dunewood	N/A
Sanibel Maple	Wilsonart 7908-60 Sanibel Maple	Panolam W158, Flakeboard H624
Fusion X	Pionite WM971S-Sugar Maple or Wilsonart 7909-60 Fusion Maple	Panolam W268 Fusion Maple
American Natural	Formica 756-58 Natural Maple	Panolam W140 Riviera Maple
Sugar Maple	Arborite 764, Wilsonart 7062-60	Uniboard 764, Panolam W690 Edgewood Sycamore
Pear Matte	Arborite 971, Wilsonart 7929-38	Uniboard 971, Panolam W272 Nutmeg Cherry
Auburn Pear	Pionite WX031 Pearwood	Flakeboard WX031 Pearwood
Hayward Cherry	Pionite WC421, Formica 5904-43	Flakeboard WC421 Oiled Cherry
Solar Oak	Wilsonart 7816-60 Solar Oak	N/A
Cognac	Pionite HP336, Tafisa 420	Panolam W336 Sunset, L420 Tafisa Summer Flame
Port Maple	Arborite 765, Formica 7008-43	Uniboard 765

PLEASE NOTE THAT THE ABOVE MATCHES ARE ONLY POSSIBLE SUGGESTIONS. TO ENSURE AN EXACT MATCH, FOIL CAN BE PURCHASED WITH YOUR ORDER. THE FOIL IS 50" WIDE AND CAN BE PURCHASED IN ANY LENGTH.

## COLORS AVAILABLE

### CATEGORY 4

VINYL	LAMINATE	MELAMINE
Aluminum	Pionite PFA60 Negotiating In Geneva	Panolam A60 Negotiating In Geneva
Hardrock Maple	Pionite WM791 Hardrock Maple	Panolam W290 Hardrock Maple
Candlelight	Tafisa L421 Candlelight	Tafisa L421 Candlelight
Desert Glow	Tafisa L421 Candlelight	Tafisa L421 Candlelight
Light Pear	Nevamar WM000ST Siren Maple	N/A
Amberwood	Nevamar WM8342T Amber Pearwood	Panolam W181 Amberwood
Rustik Cherry**	Tafisa L521 Rustik Cherry	Tafisa L521 Rustik Cherry
Medium Cherry	Pionite WC421-S Oiled Cherry or Nevamar WC-5581 N Blossom Cherry	Panolam Oiled Cherry
Mahogany Impressions	Pionite HP365 Mahogany Impressions	Panolam W365 Mahogany Impressions
Windsor Mahogany	Wilsonart 7039-60 Windsor Mahogany	Panolam W372 Mahogany
Cayenne Maple	Pionite Grove Myrtle 687	Panolam W687 Grove Myrtle or Uniboard 766 Cayenne Maple
Chocolate Peartree	Tafisa L444 Chocolate Pear	Tafisa L444 Chocolate Pear

### CATEGORY 5

VINYL	LAMINATE	MELAMINE
White Gloss	Formica 949-90 White	N/A

PLEASE NOTE THAT THE ABOVE MATCHES ARE ONLY POSSIBLE SUGGESTIONS. TO ENSURE AN EXACT MATCH, FOIL CAN BE PURCHASED WITH YOUR ORDER. THE FOIL IS 50" WIDE AND CAN BE PURCHASED IN ANY LENGTH.

\*\*NEW ITEM - SPECIAL ORDER ONLY\*\*

## COLORS AVAILABLE

### GLAZED COLORS

GLAZE/VINYL	LAMINATE	MELAMINE
Chocolate Brown on Antique White		
Detail	Tafisa L303 Hardrock Maple	Tafisa L443 Secret
Rustic	Wilsonart 7909-60 Fusion Maple Tafisa L443 Secret	Panolam W140 Riviera Maple
Auburn Red on Light Pear		
Detail	Wilsonart 10745-60 Fonthill Pear	Panolam W338 Sunrise
Rustic	Formica 7484-58 Cherry Birch	Panolam W338 Sunrise
Chocolate Brown on Light Pear		
Detail	Tafisa L421 Candlelight	Tafisa L421 Candlelight
Rustic	Pionite WM951-S Honeymaple Suede	Uniboard 205 Tobacco Cherry
Onyx on Medium Cherry		
Detail	Tafisa L420 Summerflame	Panolam W336 Sunset
Rustic	Tafisa L420 Summerflame Pionite HP336 Sunset	Tafisa L420 Summerflame

PLEASE NOTE THAT THE ABOVE MATCHES ARE ONLY POSSIBLE SUGGESTIONS.